

BEIJING HUADE HYDRAULIC INDUSTRIAL GROUP CO.,LTD.	<b>Pilot operated check valves, Types SV and SL...40B/ (new series)</b>			RE 21500/12.2004
	Size 10 to 32	up to 31.5 MPa	up to 550L/min	

**Features:**

- check valve controlled by fluid
- For subplate mounting, Mounting pattern to DIN 24 340
- Subplate or screw threaded connection
- With or without leakage port
- With or without pre-opening
- Type with pre-opening, dampened decompression
- 4 opening pressures
- Porting pattern to Din 24 340 form A, ISO 4401 and CETOP-RP 121H



**Function, section, symbols**

SV and SL valves are hydraulic pilot operated check valves in poppet type design which may be opened to allow flow in either direction.

These valves are used for the isolation of operating circuits under pressure, as safeguard against the lowering of a load when a line break occurs or against creeping movements of hydraulically locked-in actuators.

Basically these valves consist of housing (1), poppet (2), compression spring (3), control spool (4) as well as a preopening, as ball poppet valve (5), optionally.

The valve enables free flow from A to B, in the counter direction the poppet (2) is held on its seat by the system pressure, additionally to the spring force.

Through the pressure connection at control port X the control piston (4) is moved to the right. This pushes the poppet (2) from the seat. Now the valve may also have a flow from B to A.

In order to ensure the proper opening of the valve via the control piston (4) a certain minimum control pressure is necessary

**Type SV..A.. and SL..A.. (with pre-opening, section 1)**

This valve has a additional pre-opening. Through pressure connection at control port X the control piston (4) is pushed to the right.

This first pushes the ball (5) and then the poppet (2) from the seat. Now the valve may also have a flow from B to A. Because of the pre-opening there is a dampened decompression of the fluid under pressure. Through this possible pressure shocks are avoided.

**Type SL... (with leakage port, section 2)**

The function of this valve is principally the same as the valve SV. The difference is the additional leakage port Y. With this the annulus area of the control piston (4) is separated from port A. The pressure present at port A only effects area A<sub>4</sub> of the control piston (4).

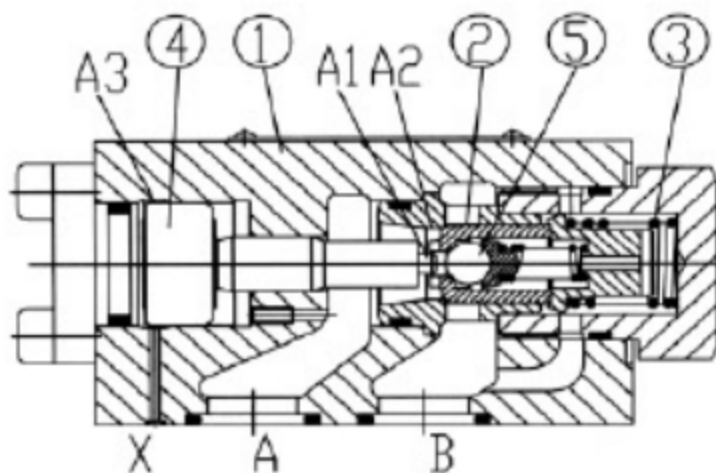

Type SV..PA (without leakage port, with pre-opening)

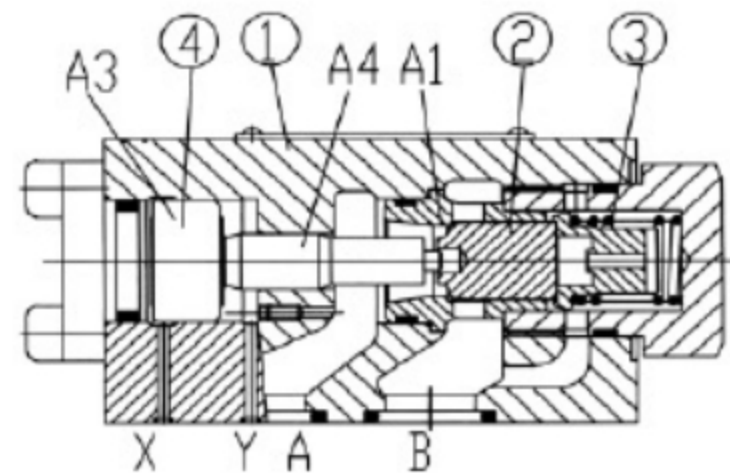

Type SL..PB (with leakage port, without pre-opening)

Symbols:  
Type SV

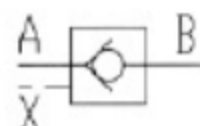

Type SL

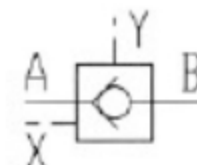



**Characteristic curves** (measured at  $v = 41 \text{ mm}^2/\text{s}$  and  $t = 50 \text{ }^\circ\text{C}$ )

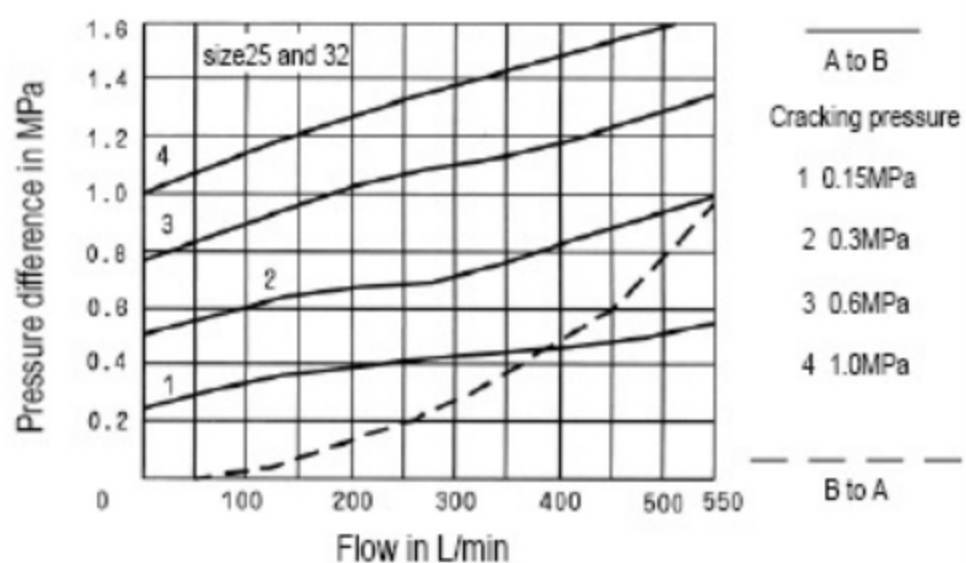
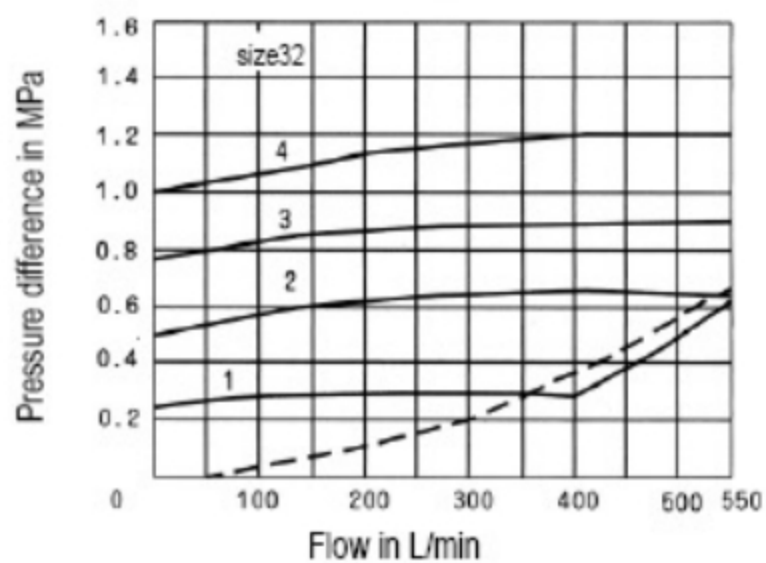
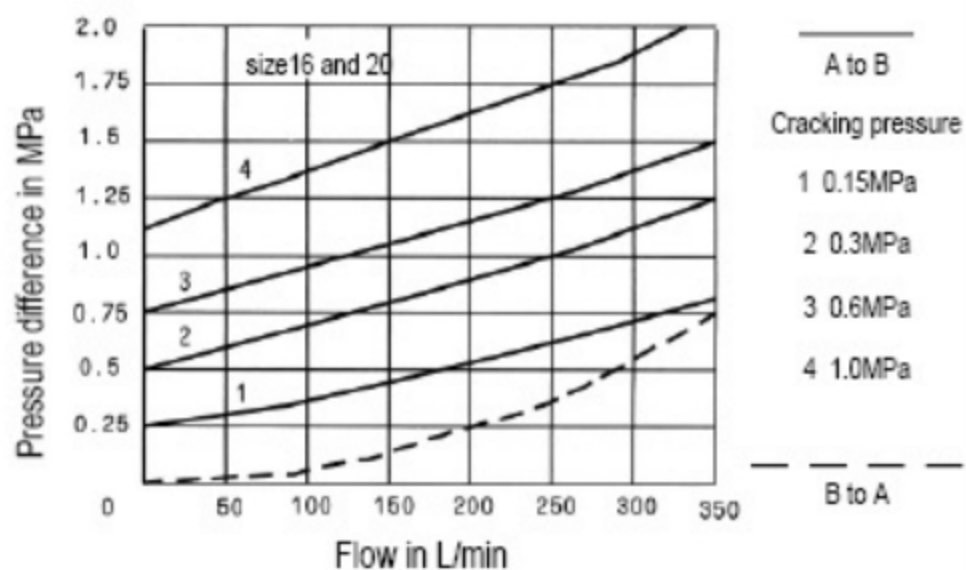
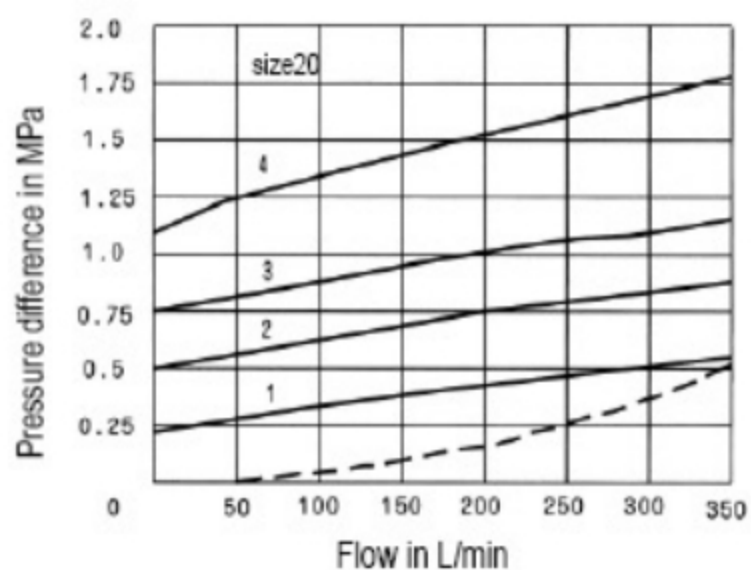
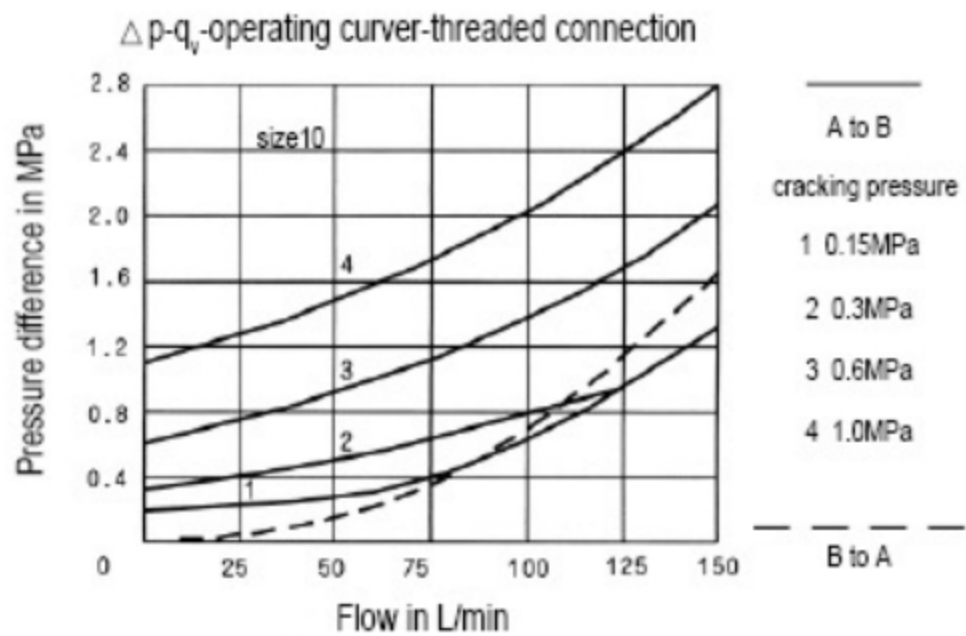
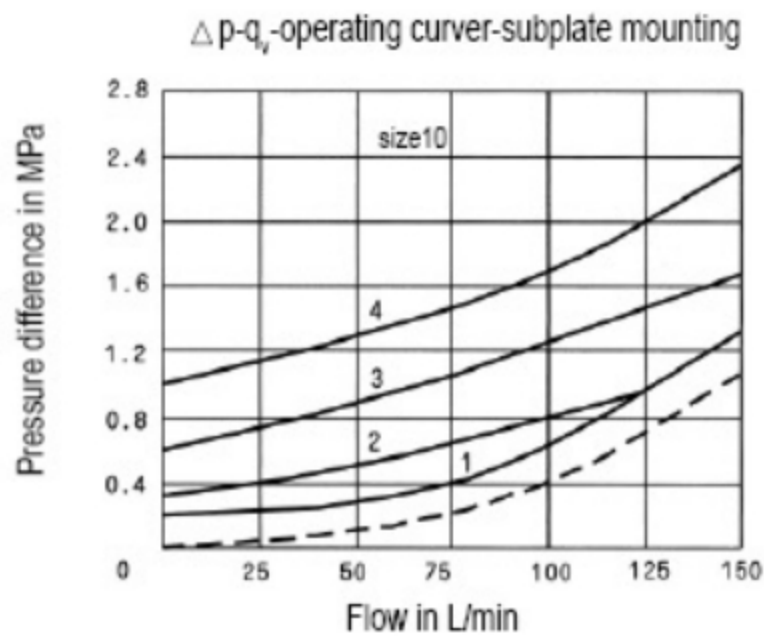

Control pressure-load pressure-operating curves

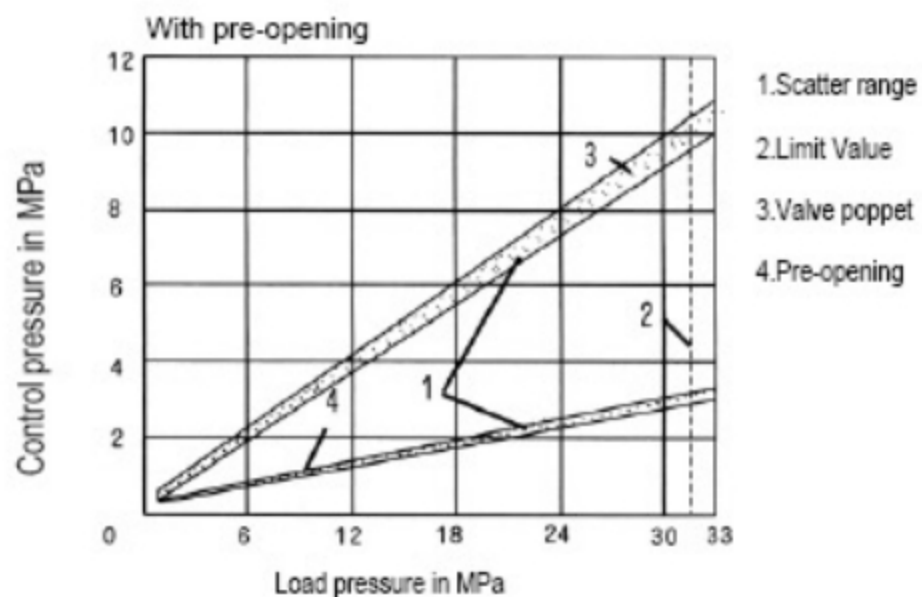
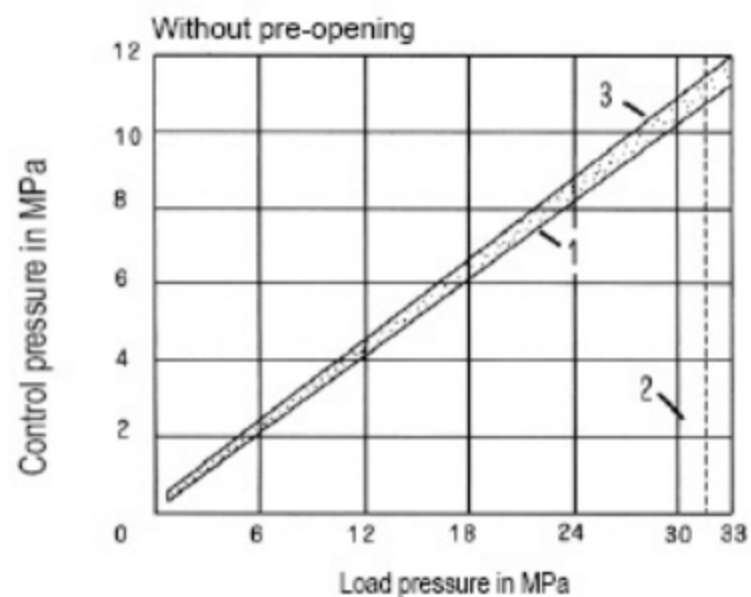

**Unit dimensions: for subplate mounting**

**(Dimensions in mm)**

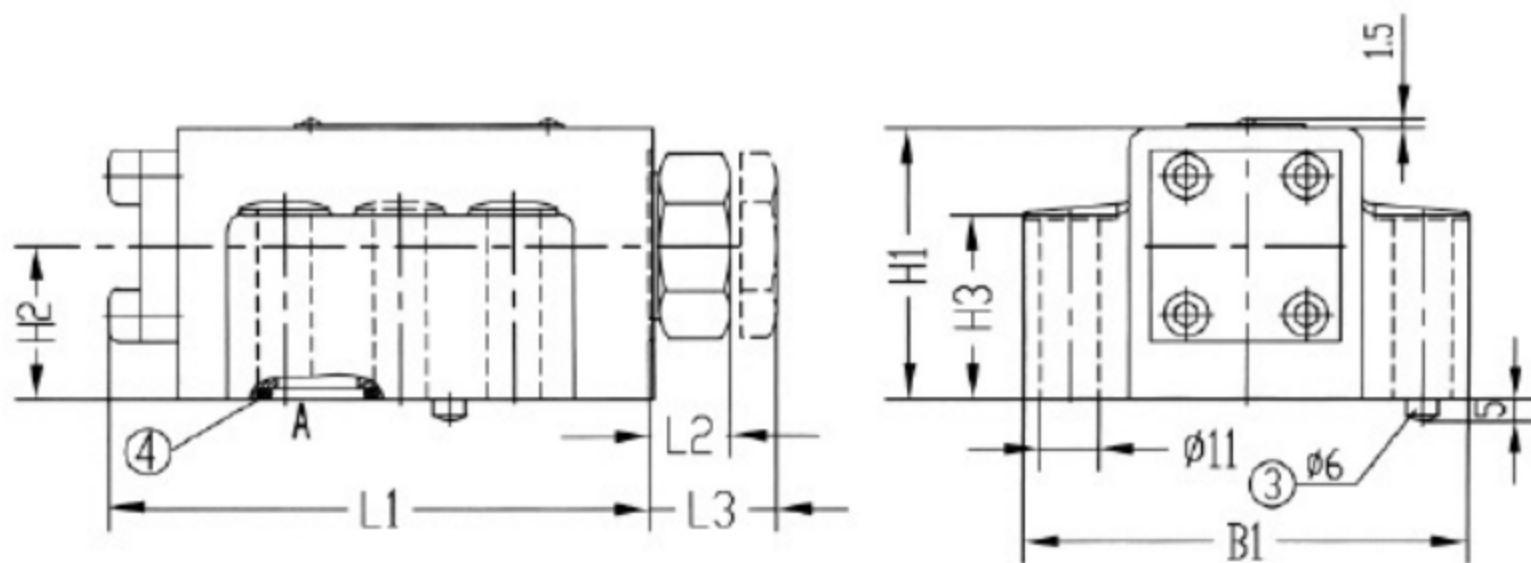

- 1 Port Y with valve type "SL"  
(with valve type "SV" this port is closed)
- 2 Name plate
- 3 Fixing pin
- 4 O-ring  
Size10  
-ports A and B 17.12X2.62  
-ports X and Y 9.25X1.78  
Size20  
-ports A and B 28.17X3.53  
-ports X and Y 9.25X1.78  
Size32  
-ports A and B 34.52X3.53  
-ports X and Y 9.25X1.78
- 5 Valve with opening pressure types "1" and "2" (dimension L2)
- 6 Valve with opening pressure types "3" and "4" (dimension L3)
- 7 6 valve fixing holes with type SV/SL 30 (valves fitting screws included in goods)  
Size10  
4 M10 × 50-10.9 (GB/T70.1-2000) M<sub>a</sub>=75N.m  
Size20  
4 M10 × 70-10.9 (GB/T70.1-2000) M<sub>a</sub>=75N.m  
Size30  
6 M10 × 85-10.9 (GB/T70.1-2000) M<sub>a</sub>=75N.m

Valve type	Size	L1	L2	L3	L4	L5	L6	L7	L8	L9	L10
SV	10	100.8	15.5	15.5	87.8	13	42.9	18.5	7.2	35.8	-
	20	135	17.7	47.7	117	18	60.3	27.5	11.1	49.2	-
	30	156.1	36.1	46.1	134	22.1	84.2	39	16.7	67.5	-
SL	10	100.8	15.5	15.5	87.8	13	42.9	18.5	7.2	35.8	21.5
	20	135	17.7	47.7	117	18	60.3	27.5	11.1	49.2	39.5
	30	156.1	36.1	46.1	134	22.1	84.2	39	16.7	67.5	59.5

Valve type	Size	L11	L12	L13	B1	B2	B3	B4	B5	H1	H2	H3
SV	10	21.5	-	31.8	84	66.7	44	58.8	-	51	29	36
	20	20.6	-	44.5	100	79.4	61	73	-	70	37	55
	30	24.6	42.1	62.7	118	96.8	75	92.8	-	85	42.5	70
SL	10	21.5	-	31.8	84	66.7	44	58.8	7.9	51	29	36
	20	20.6	-	44.5	100	79.4	61	73	6.4	70	37	55
	30	24.6	42.1	62.7	118	96.8	75	92.8	3.8	85	42.5	70

Subplate:  
must be ordered separately. see page 204  
Size10 G460/01(G3/8") G461/01(G1/2")  
Size20 G412/01(G3/4") G413/01(G1")  
Size30 G414/01(G1 1/4") G415/01(G1 1/2")

Required surface finish of mating piece

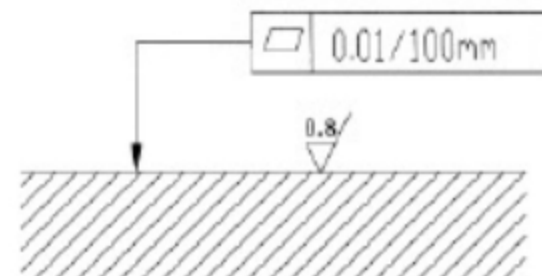

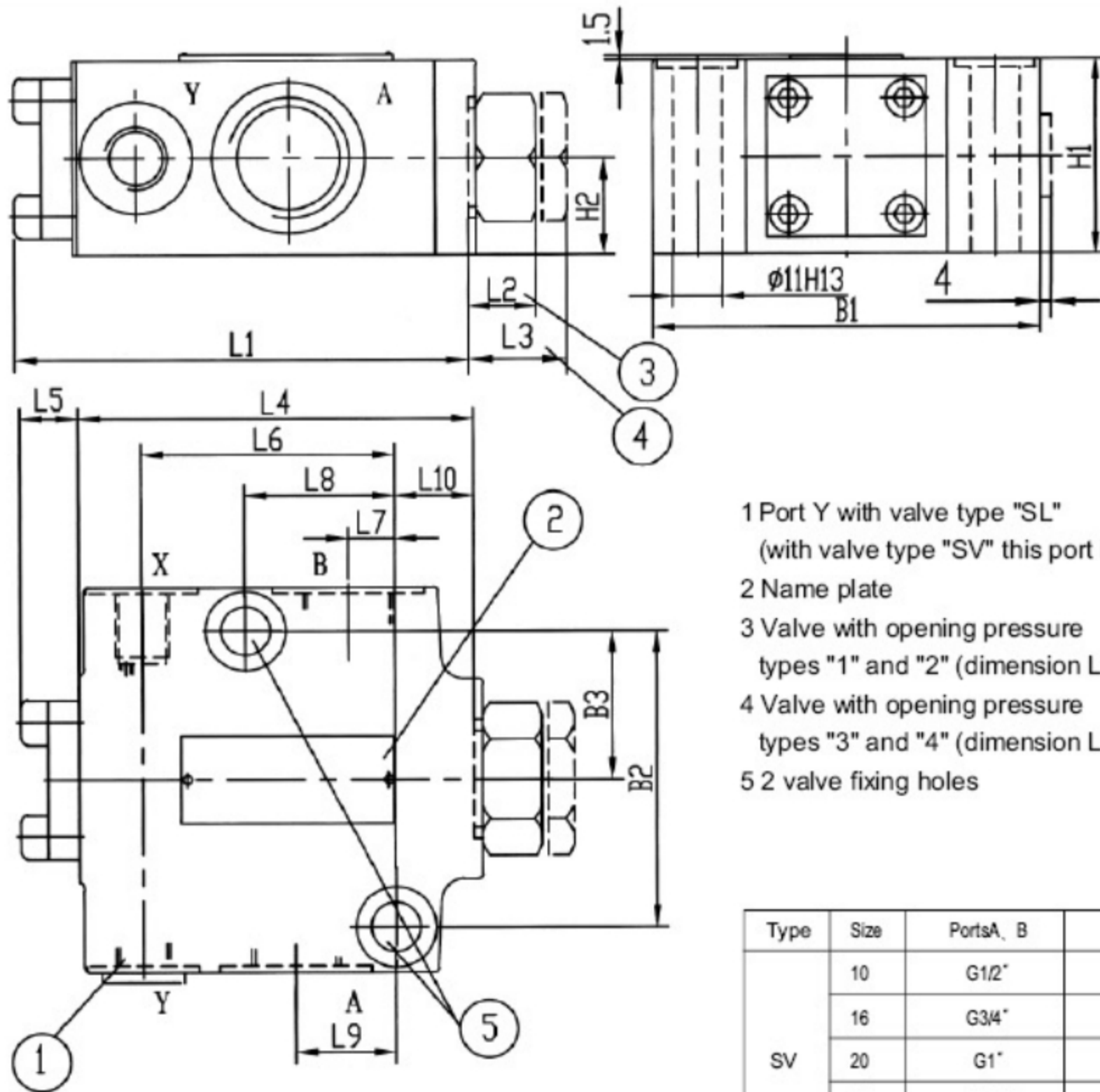

- 1 Port Y with valve type "SL"  
(with valve type "SV" this port is closed)
- 2 Name plate
- 3 Valve with opening pressure types "1" and "2" (dimension L2)
- 4 Valve with opening pressure types "3" and "4" (dimension L3)
- 5 2 valve fixing holes

Type	Size	Ports A, B	Ports X, Y
SV	10	G1/2"	G1/4"
	16	G3/4"	G1/4"
	20	G1"	G1/4"
	25	G1 1/4"	G1/4"
	30	G1 1/2"	G1/4"
SL	10	G1/2"	G1/4"
	16	G3/4"	G1/4"
	20	G1"	G1/4"
	25	G1 1/4"	G1/4"
	30	G1 1/2"	G1/4"

Valve type	Size	L1	L2	L3	L4	L5	L6	L7	L8	L9	L10	B1	B2	B3	H1	H2
SV	10	100.8	15.5	15.5	87.8	13	56.5	10.5	33.5	22.5	17.3	87	66.7	33.4	44	22
	16;20	133	17.7	47.7	115	18	74.5	17	50.5	36	27	105	79.4	39.7	68	34
	25;32	156.1	35.7	45.7	134	22.1	101	24	84	49	18	130	96.8	48.4	85	42.5
SL	10	100.8	15.5	15.5	87.8	13	56.5	10.5	33.5	22.5	17.3	87	66.7	33.4	44	22
	16;20	133	17.7	47.7	115	18	74.5	17	50.5	36	27	105	79.4	39.7	68	34
	25;32	156.1	35.7	45.7	134	22.1	101	24	84	49	18	130	96.8	48.4	85	42.5

## Notice

1. The fluid must be filtered. Minimum filter fineness is 20  $\mu\text{m}$ .
2. The tank must be sealing up and an air filter must be installed on air entrance.
3. Products without subplate when leaving factory, if need them, please ordering specially.
4. Valve fixing screws must be high intensity level (class 10.9). Please select and use them according to the parameter listed in the sample book.
5. Roughness of surface linked with the valve is required to  $\frac{0.8}{\sqrt{\text{ }}$ .
6. Surface finish of mating piece is required to 0.01/100mm.