

BEIJING HUADE HYDRAULIC INDUSTRIAL GROUP CO.,LTD.	Double throttle/check valve, Type Z2FS Series 30			RE:27505/12.2004
	Sizes 6, 16, 22	up to 31.5MPa	up to 350 L/min	Replaces: RE27505/5.2001

Features:

- Sandwich plate design
- Porting pattern to DIN 24 340, from A,ISO 4401 and CETOP-RP 121H
- Limiting of main or pilot flow with two service ports,
- Meter-in or meter-out control.

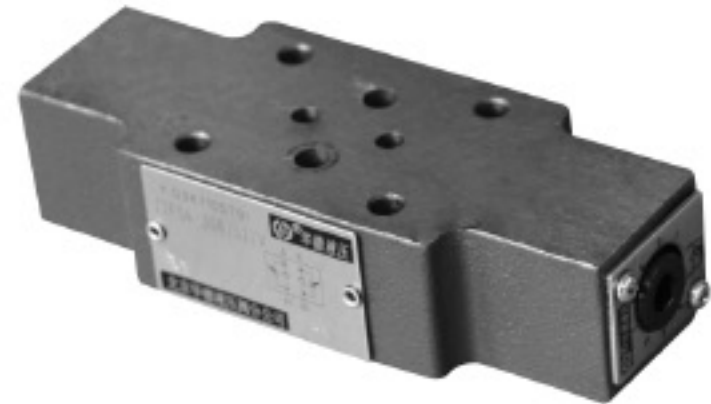

Functional , Section

Valves type Z 2 FS are double throttle/check valves in sandwich plate design.They are used to limit main or pilot oil flow at one or two service ports.Two symmetrically arranged throttle/check valves limit flow (by means of adjustable throttle spools) in one direction and permit free return flow in the other direction.

Main flow limiting

The double throttle/check valve is fitted between the directional valve and the subplate to change the speed of an actuator (main flow limiting).

Pilot flow limiting

In the case of pilot operated directional valves, the double throttle/check valve may be used as a pilot choke adjustment (pilot flow limiting). In this case, it is fitted between the main valve and the pilot valve.

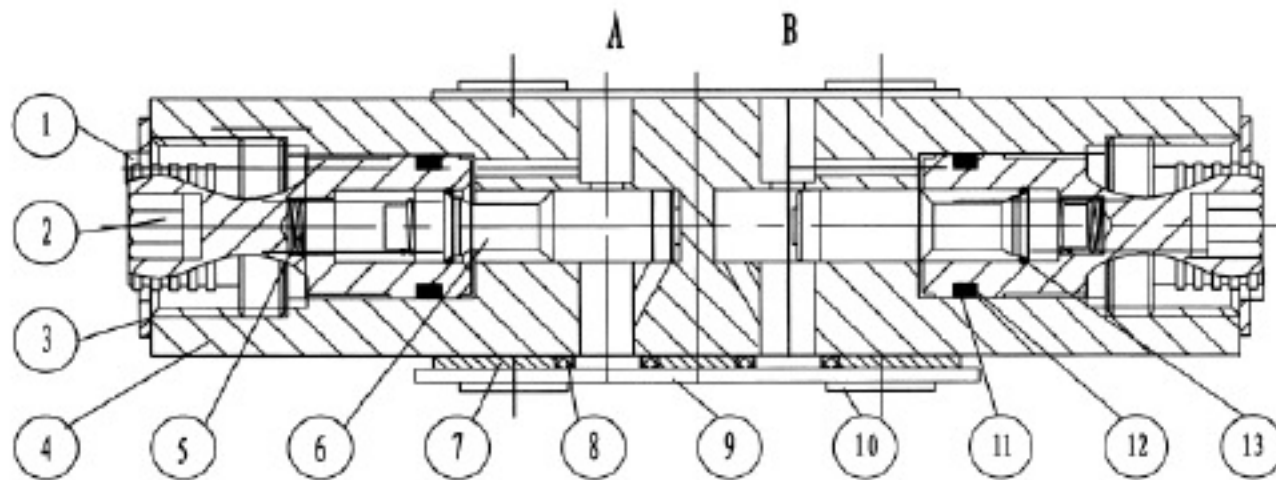

Double throttle/check valve, Type Z2FS6

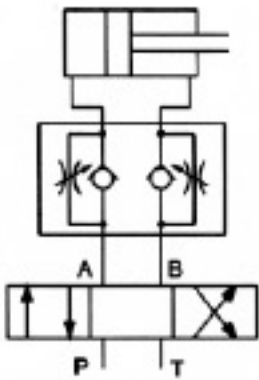
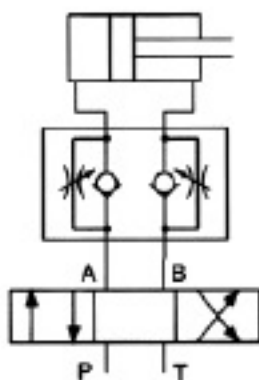
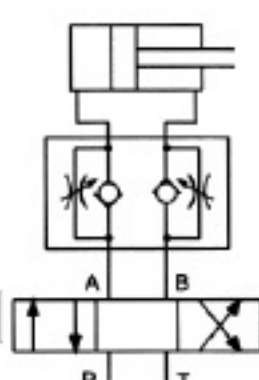
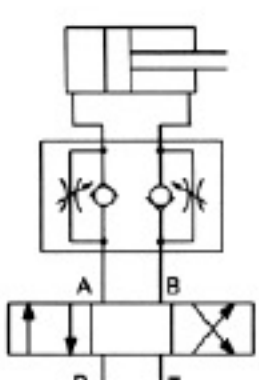
Meter-in control: S	Meter-out control: S2	A Meter-out control B Meter-in control:S3	A Meter-in control B Meter-out control:S4
			

Principle of Hydraulic systems

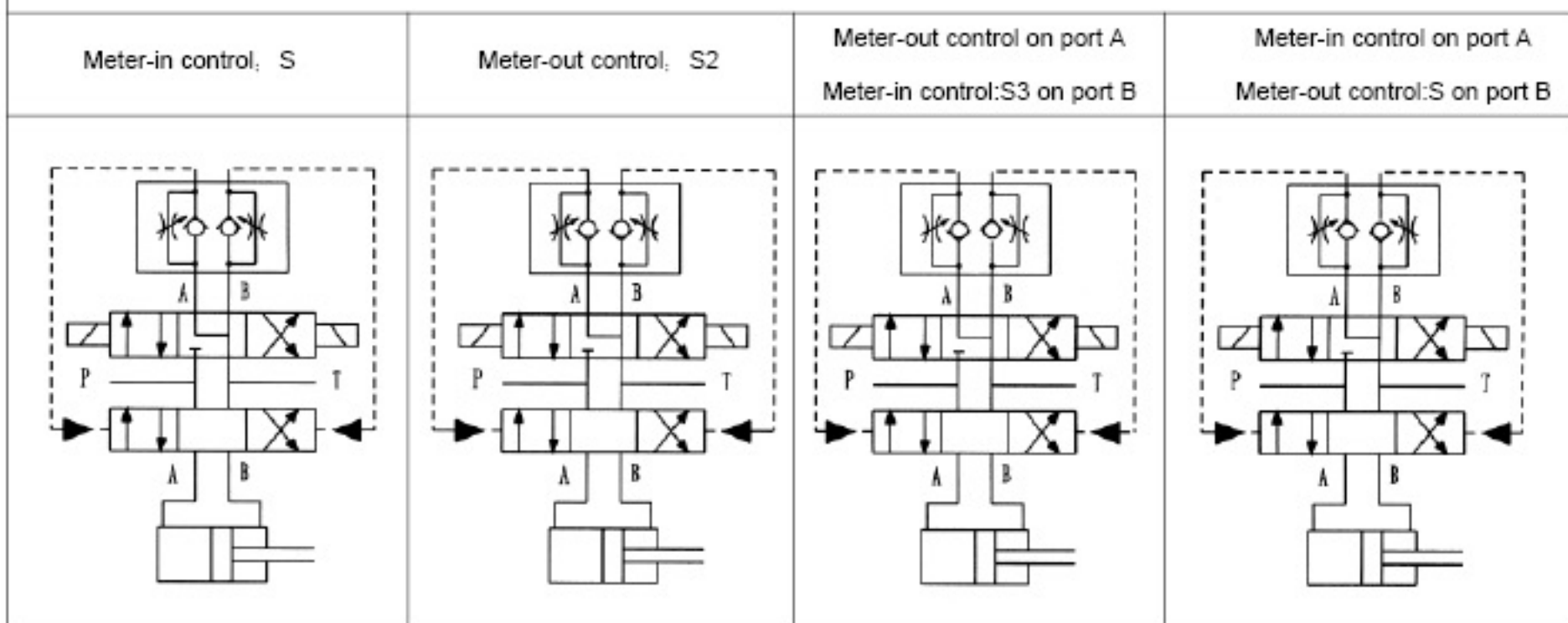

Ordering details

Z2FS -30 B / *

Double throttle/check valve		Further details in clear text
Nominal size 6 = 6		No code = Mineral oil
Nominal size 16 = 16		V = Phosphate ester
Nominal size 22 = 22		
Series 30 to 39 =30 (30 to 39: unchanged installation and connection dimensions)		No code = (With two throttle/check valves)
		S = Meter-in
		S2 = Meter-out
		S3 = Meter-out on port A, meter-in on port B
		S4 = Meter-in on port A, meter-out on port B
Technology of Beijing Huade Hydraulic =B		

Technical data (for applications outside these parameters, please consult us!)

Size	6	16	22
Maximum flow (L/min)	80	250	350
Maximum working pressure (MPa)	31.5	35	
Pressure fluid	Mineral oil (for NBR seal) or Phosphate ester (for FPM seal)		
Viscosity range (mm ² /s)	10 to 800		
Fluid temperature range (°C)	-30 to +80		

Characteristic curves (measured at $v = 41 \text{ mm}^2/\text{s}$ and $t = 50 \text{ }^\circ\text{C}$)

Pressure difference Δp in relationship to the flow q_v via the check valve (throttle closed)

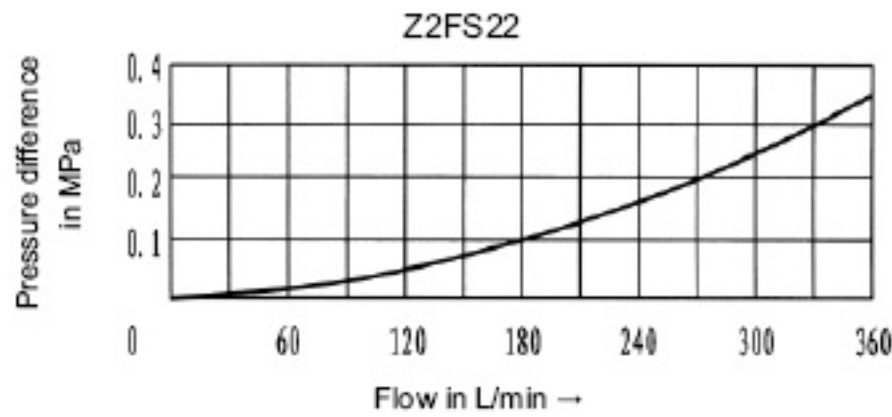
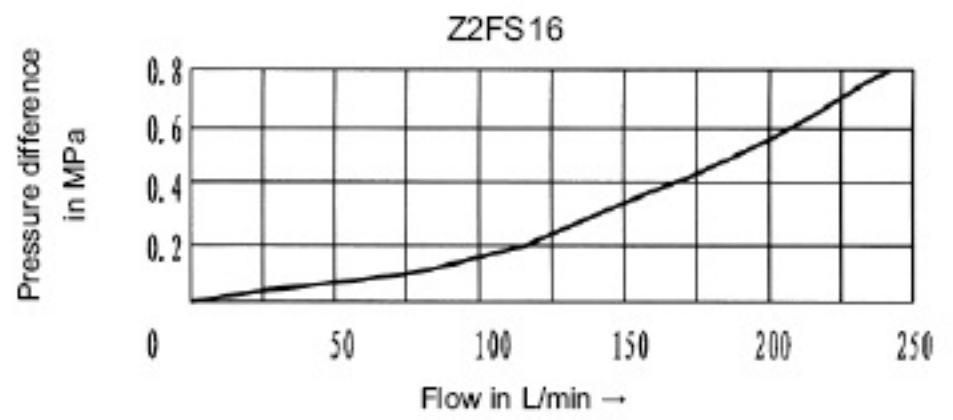
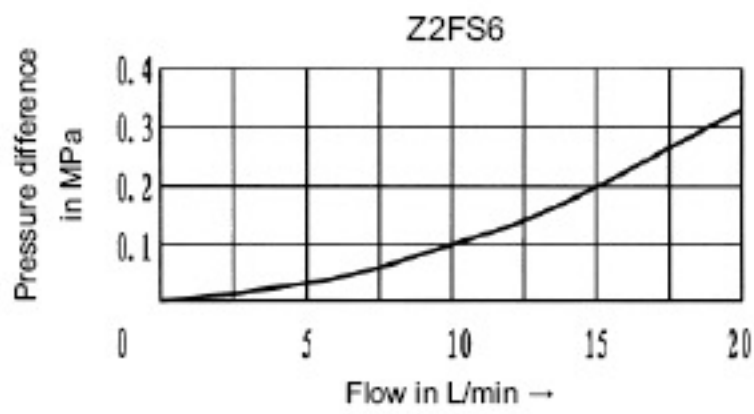

Pressure difference Δp in relationship to the flow q_v at a constant throttle setting.

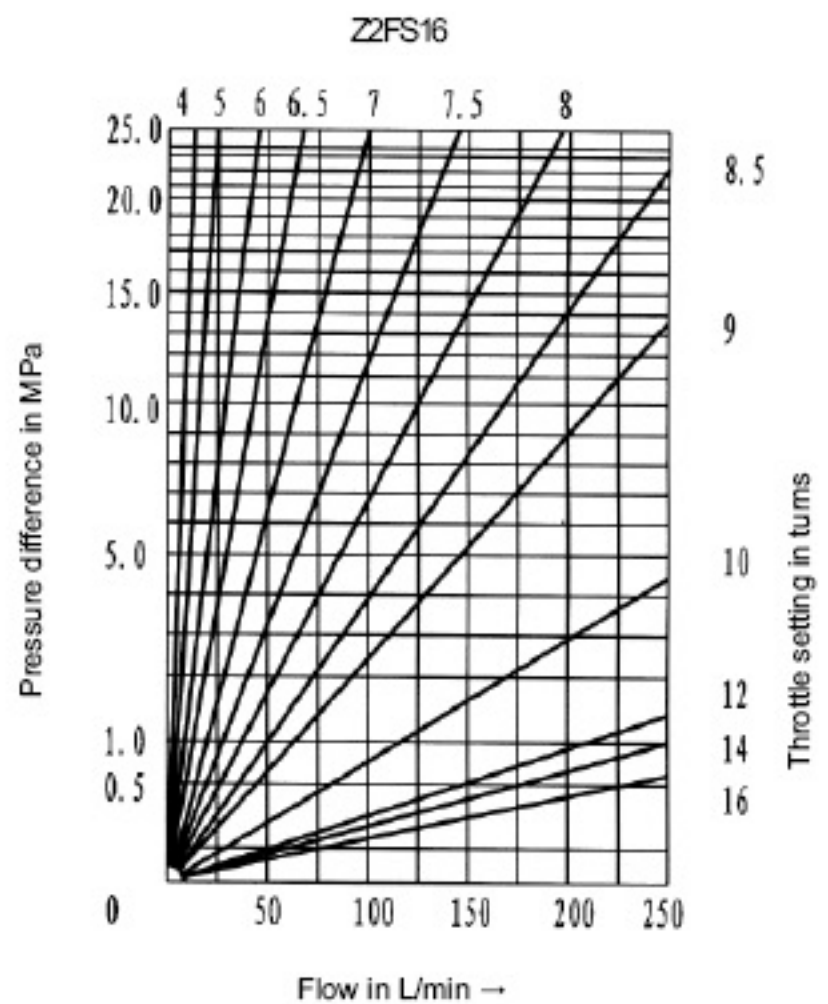
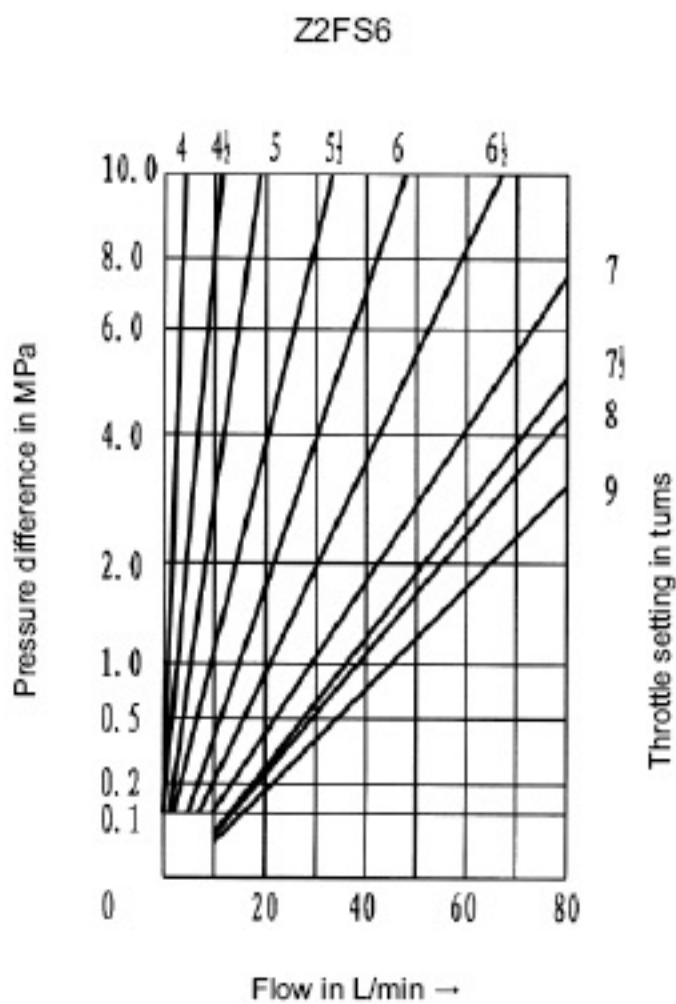

Characteristic curves (measured at $v = 41 \text{ mm}^2/\text{s}$ and $t = 50 \text{ }^\circ\text{C}$)

Pressure difference Δp in relation to the flow q_v at constant throttle setting

Z2FS22

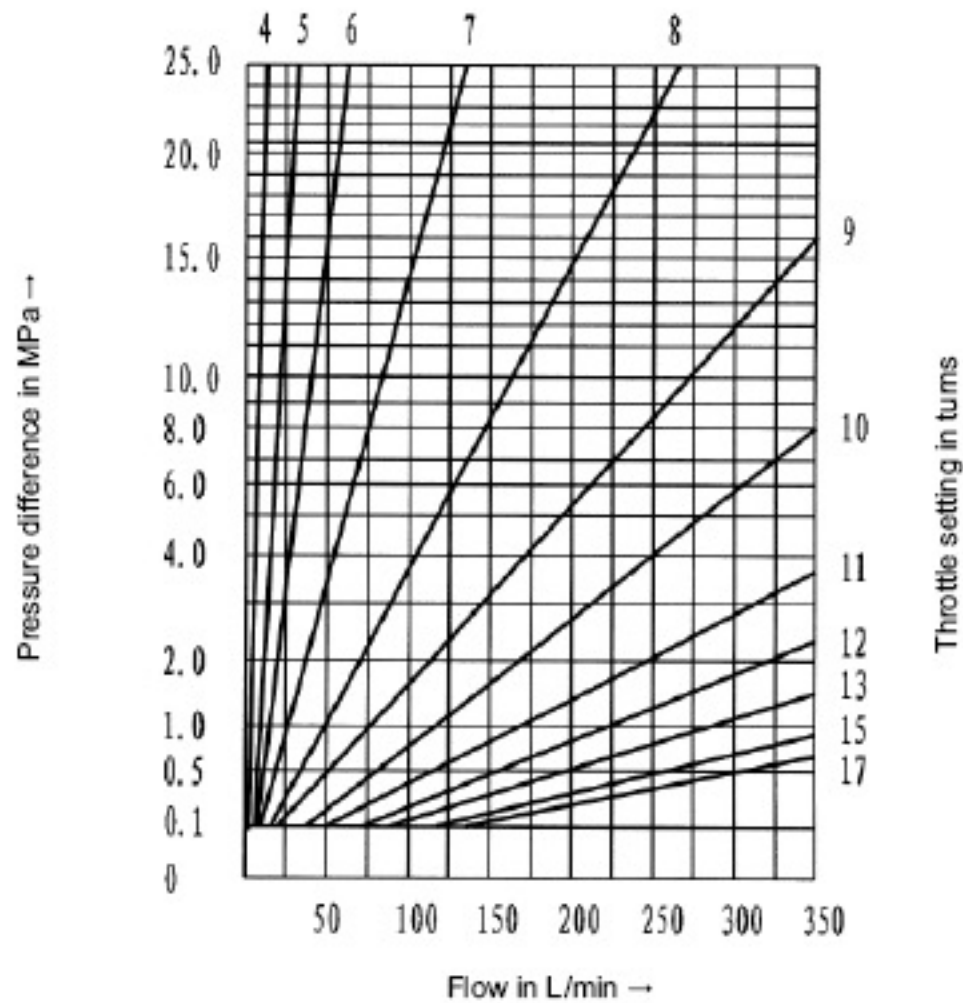

Unit dimensions

(Dimensions in mm)

Type Z2FS6:

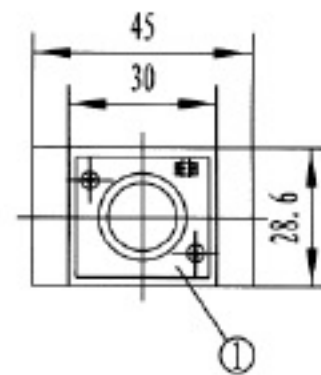
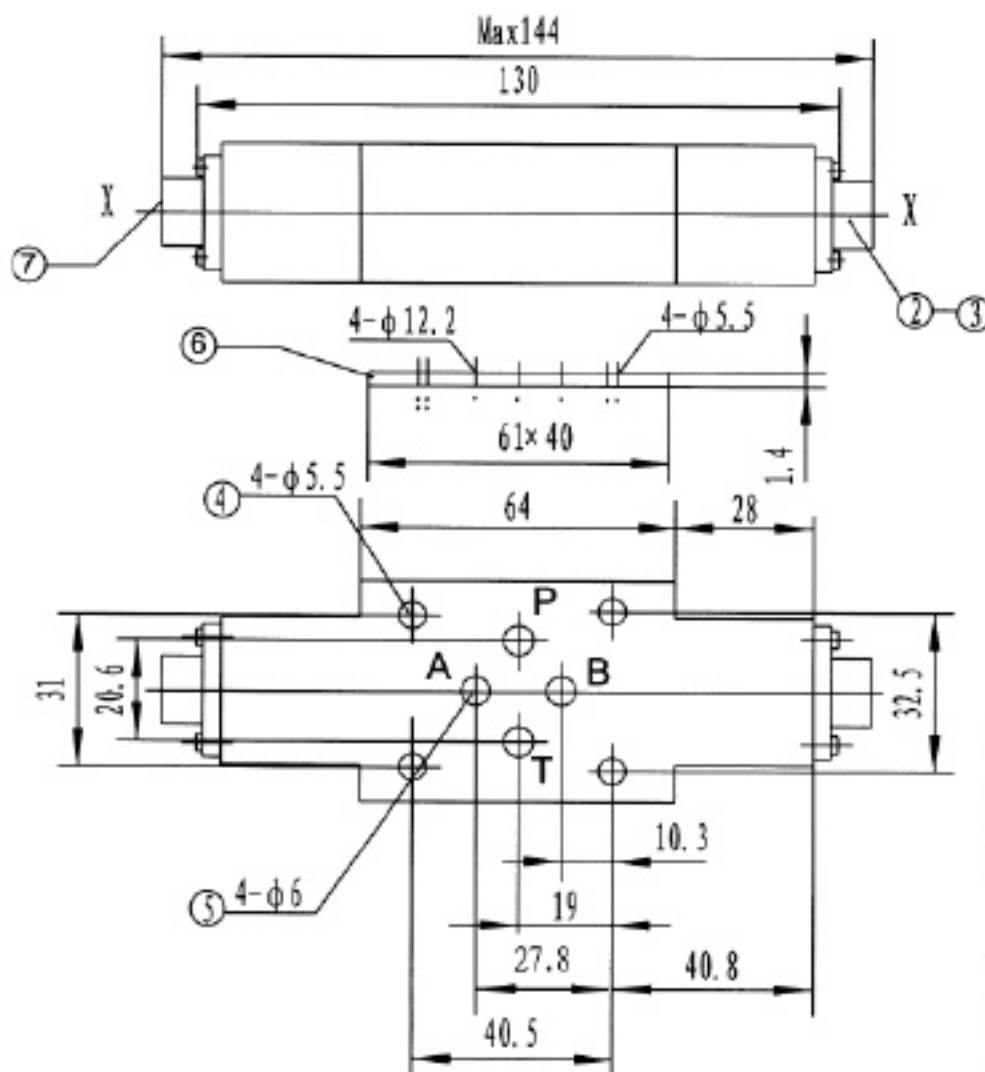

- 1 Name plate
- 2 Setting screw for alteration of flow cross section
- 3 Turn anti-clockwise = increases flow
turn clockwise = decreases flow
- 4 Valve fixing holes
- 5 Ports A, B, P, T
- 6 O-ring plate
- 7 To change from meter-in to meter-out, rotate the unit about the "X"- "X" axis

Unit dimensions

(Dimensions in mm)

Type Z2FS16:

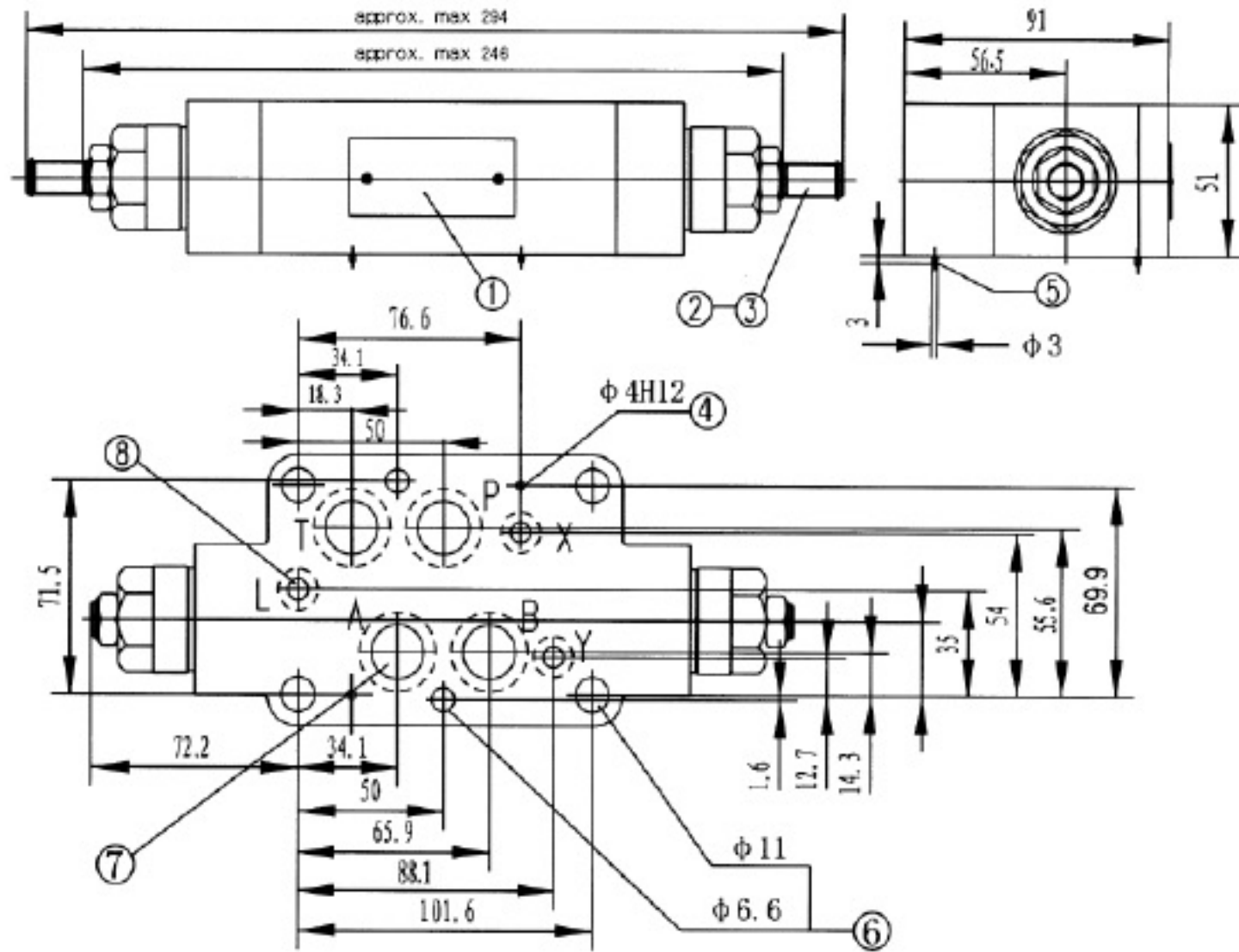

Type Z2FS22

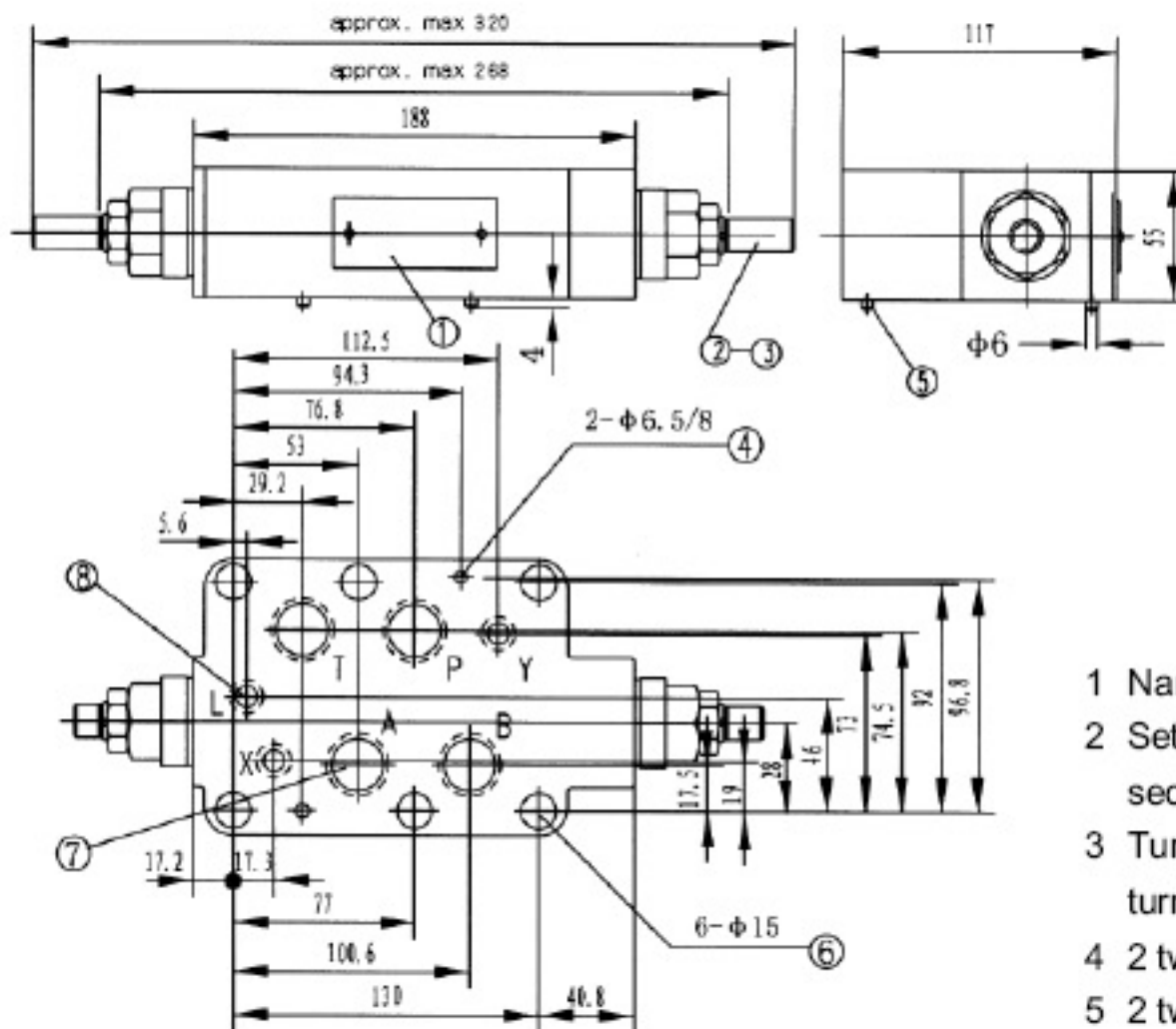

- 1 Name plate
- 2 Setting screw for alteration of flow cross section
- 3 Turn anti-clockwise = increases flow
turn clockwise = decreases flow
- 4 2 two locating pins
- 5 2 two locating pins holes
- 6 6 Valve fixing holes
- 7 O-ring for ports A, B, P, T
- 8 O-ring for ports X, Y, L

Notice

1. The fluid must be filtered. Minimum filter fineness is 20 μm .
2. The tank must be sealing up and an air filter must be installed on air entrance.
3. Products without subplate when leaving factory, if need them, please ordering specially.
4. Valve fixing screws must be high intensity level (class 10.9). Please select and use them according to the parameter listed in the sample book.
5. Roughness of surface linked with the valve is required to $\sqrt{0.8}$.
6. Surface finish of mating piece is required to 0.01/100mm.